

**BITTE BEACHTEN SIE:** Alle Säulen + Zubehör sind nur halbe Elemente und müssen daher zusammengesetzt werden um ein komplettes Stück zu ergeben. Artikelnummern gelten für den Innenbereich.  
Für den Außenbereich (Fassadenstück) fügen Sie bitte einfach ein "F" vor die Artikelnummer ein (z.B.: F + SG0022 = FSG0022).

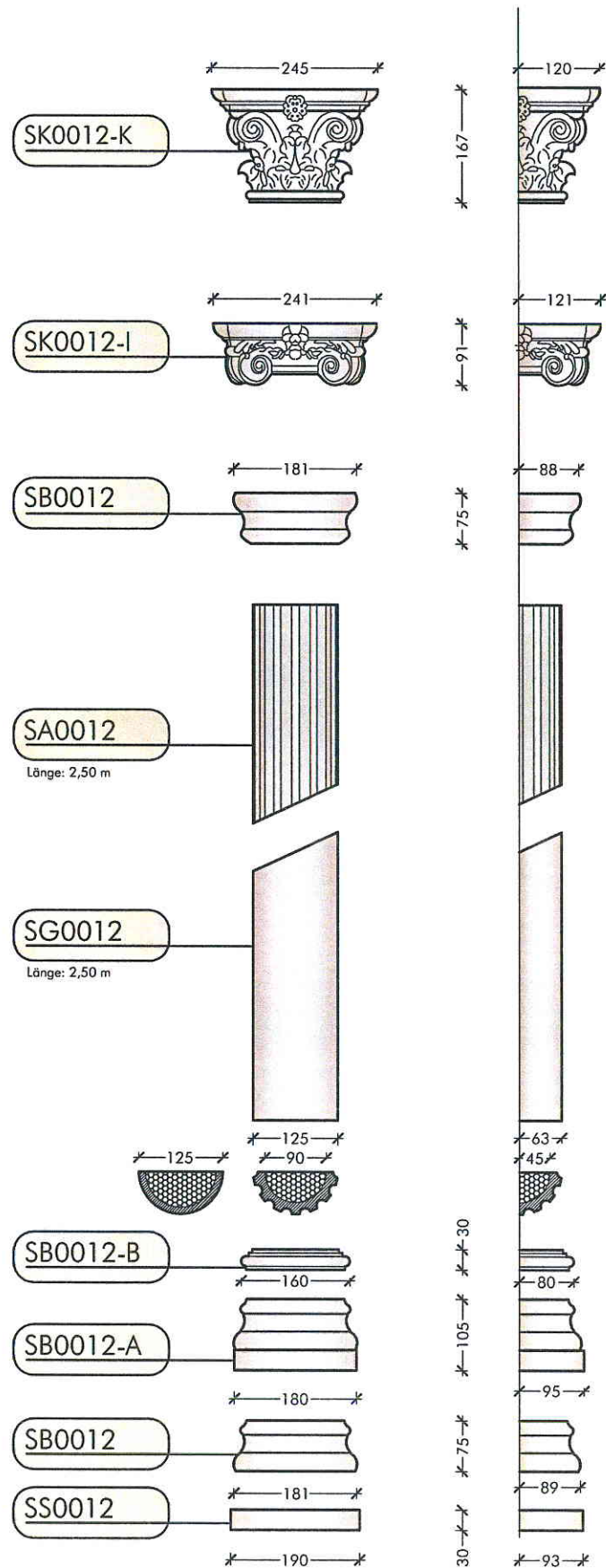

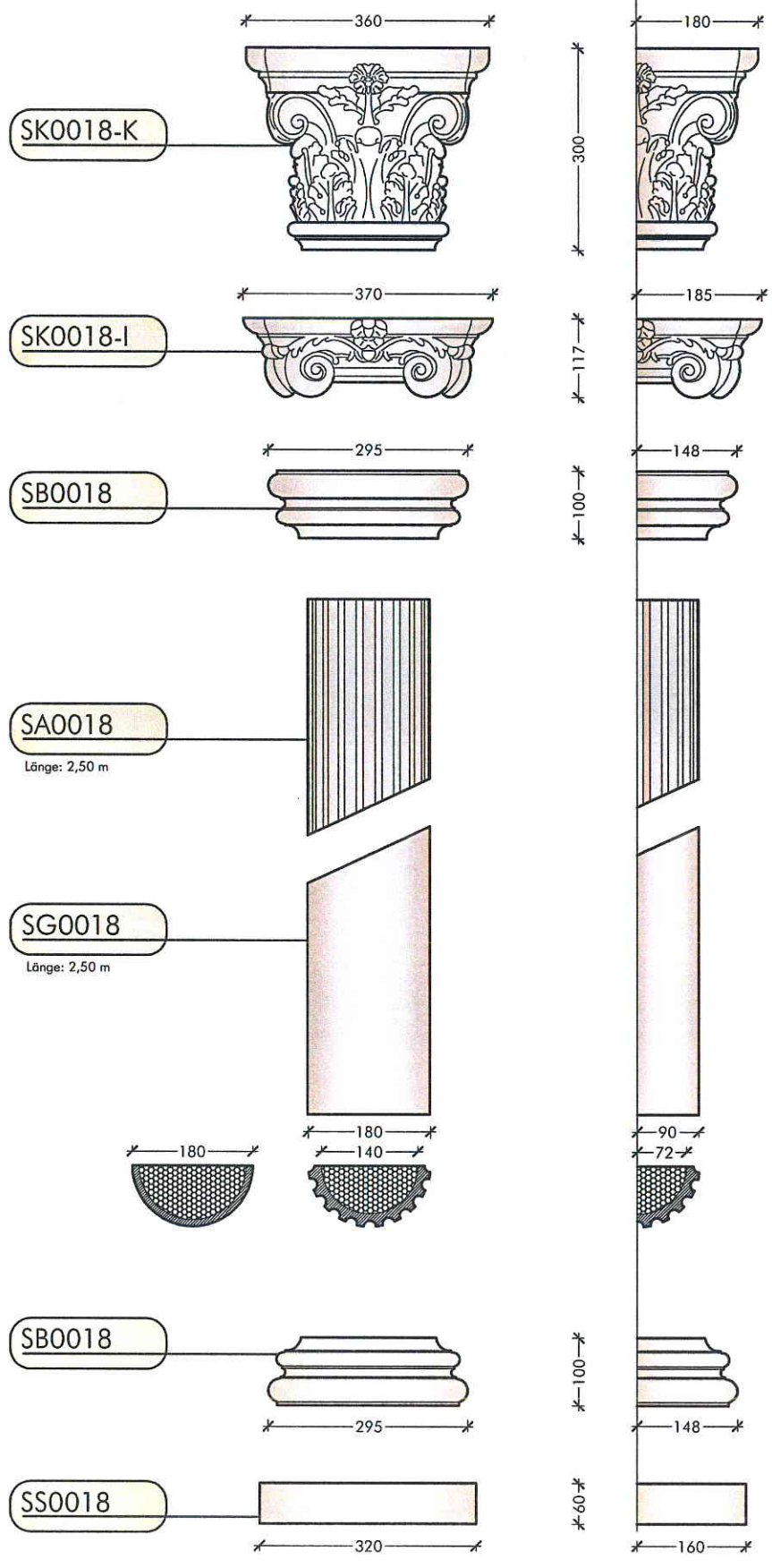

SK0022-K

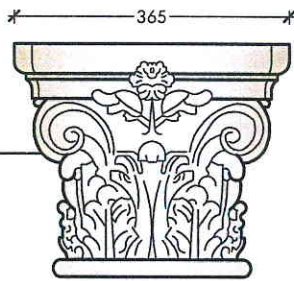

SK0022-I

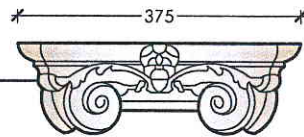

SB0022

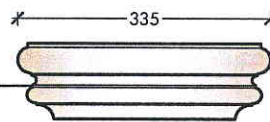

SE0022

Länge: 2,50 m

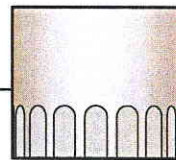

SA0022

Länge: 2,50 m

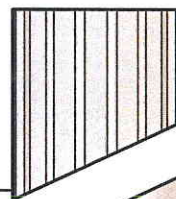

SG0022

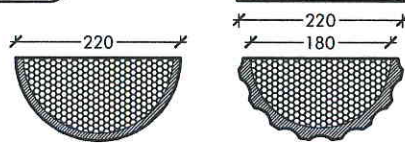
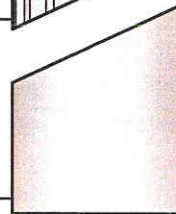

SB0022

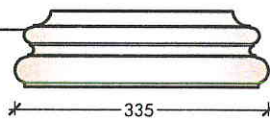

SS0022

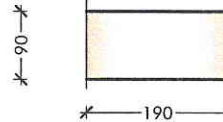
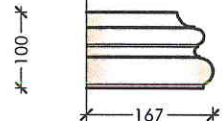
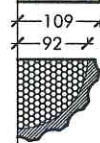
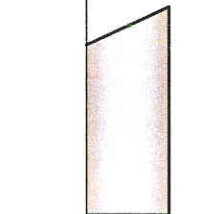
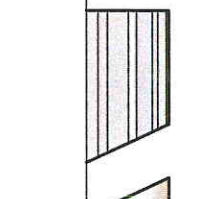
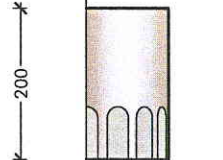
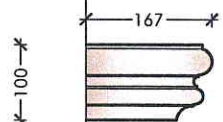
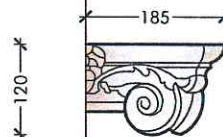
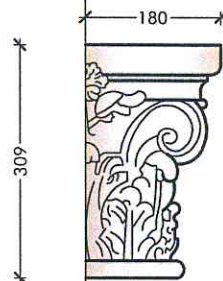
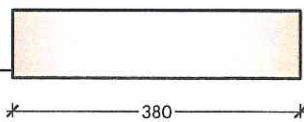

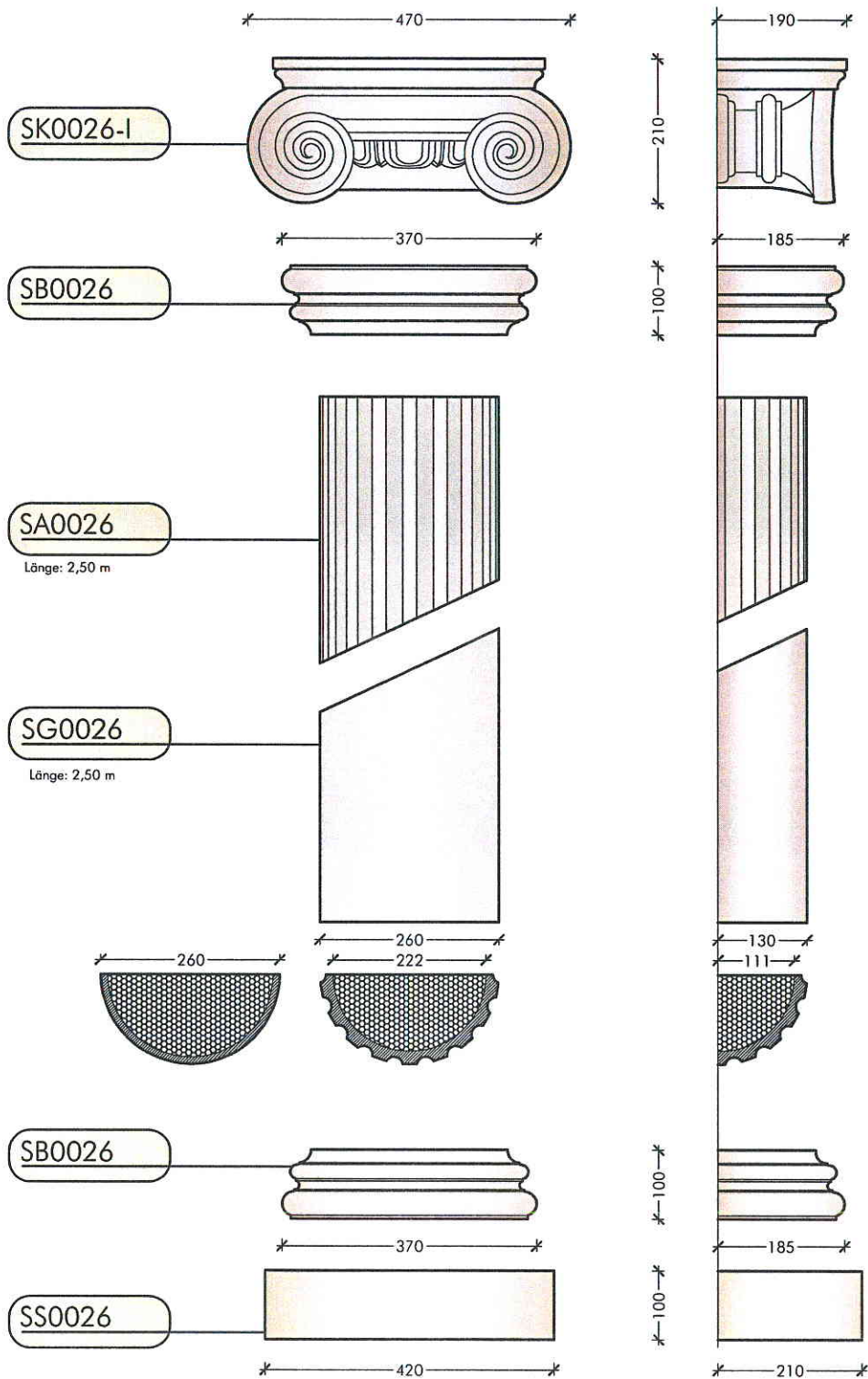

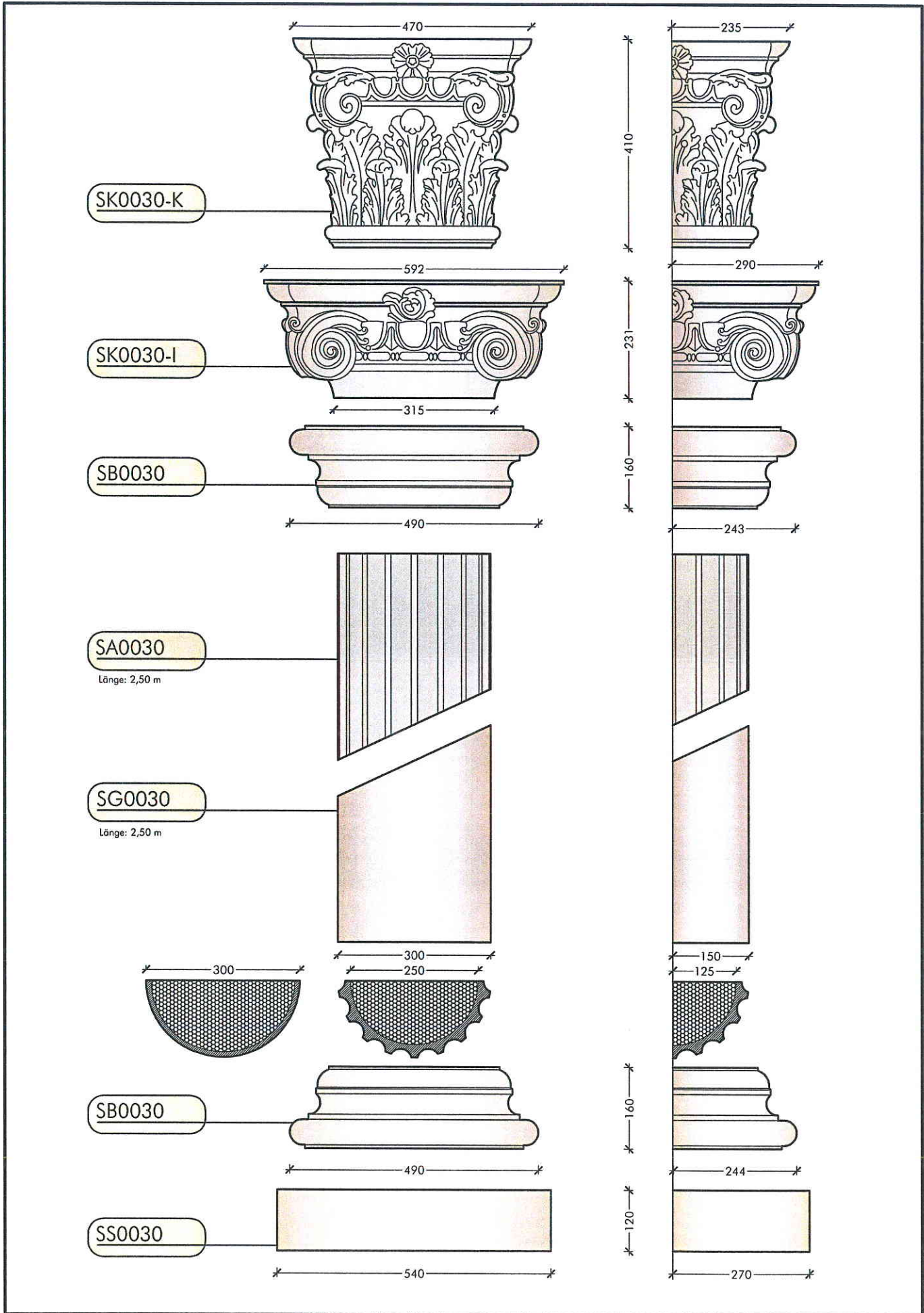

DIE WIENER STUCKMANUFAKTUR	22.07.2011	M = 1 : 10
	KHE	Säulen Seite 5